

# 5 YEAR GUARANTEED LINEAR

## Lambda LD series

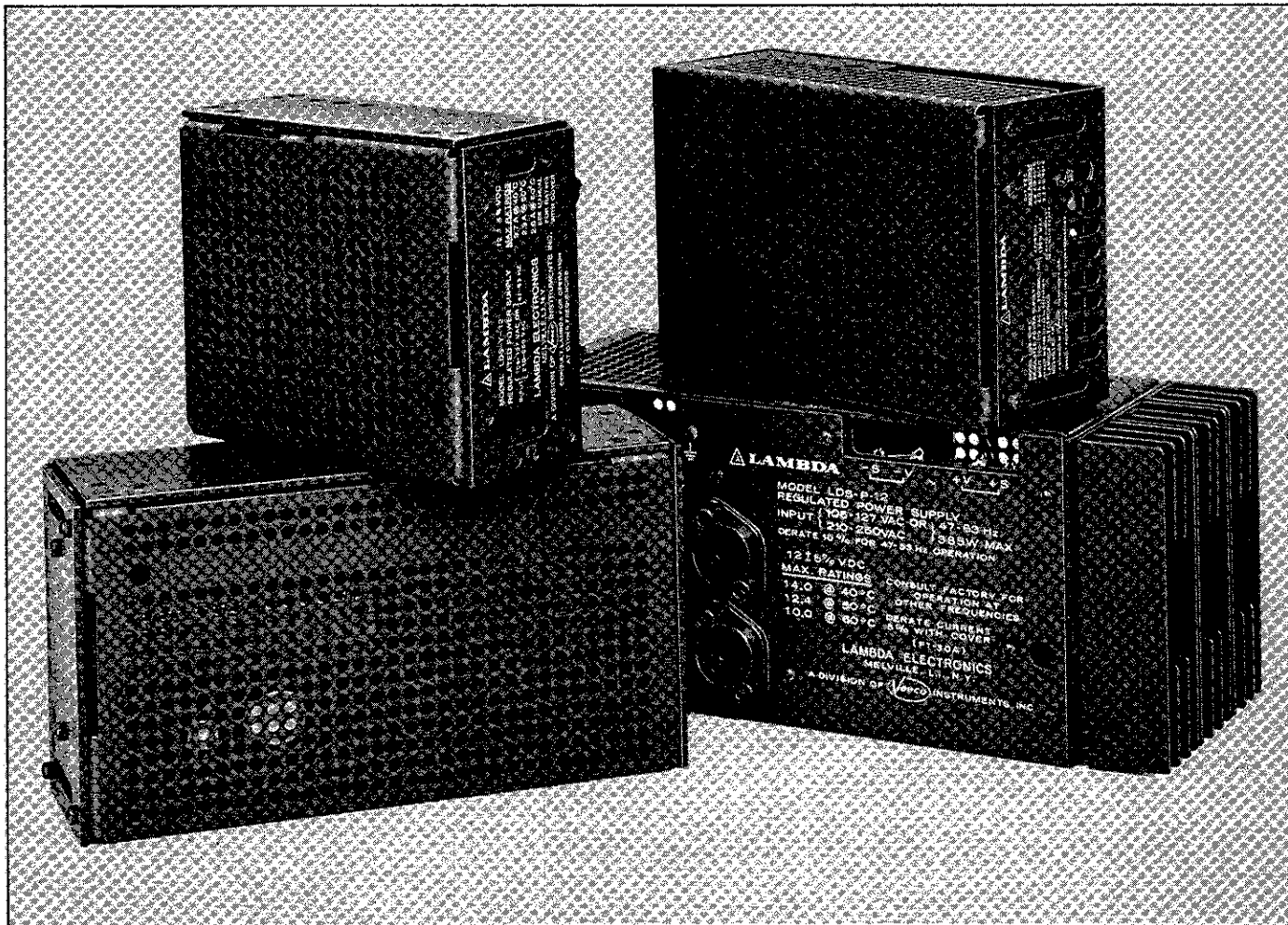

### Features — LD Series

Regulation: 0.005%  
Ripple: 150  $\mu$ V  
Temp. Coeff: 0.005%

Made possible through use of Lambda's proprietary, monolithic, multi-function voltage regulator with built-in, on-chip temperature regulator

4 package sizes, up to 150 Volts, up to 22A

Low-cost 5-year guaranteed power supplies

Convection Cooled

Lambda MIL-T-27C Grade 6 Transformer layer wound with electrostatic shield, Class H 180°C, UL approved

LD power supplies designed to meet MIL-STD-810C and MIL-I-6181D specifications

Sprague 602D high temperature, premium computer grade hermetically sealed electrolytic capacitor

Lambda heavy duty 1/8 inch thick aluminum sheet metal

Lambda CC4<sup>®</sup>\* Printed Circuit Board plated thru-holes, fungus inert, flame retardant

\*Licensee of Photo Circuits, Inc.

MIL-R-26 wire-wound resistors

MIL-W-16878 Wire UL approved

Thermostat - automatically resets when overtemperature condition is eliminated

Potentiometer fully enclosed cermet

MIL-R-22684 type film resistors

Lambda perforated 1/16 inch thick steel cover

RJ - Recognized

CSA - Certified (48V, 100V, 120V and 150V models presently under test)

# Specifications—LD Series

## DC Output

Refer to the tables.

### REGULATED VOLTAGE

regulation, line	0.005%+0.5 mV for line variations from 105 to 127 VAC.
regulation, load	0.005%+0.5 mV for load variations from 0 to full load.
ripple and noise	1mV pk-pk, 150 $\mu$ V RMS (250 $\mu$ V for 100V, 120V, 150V units)
temp. coeff.	$\pm(0.005\%+10\mu\text{V})/^{\circ}\text{C}$ on wide range models with external programming resistors. $\pm(0.01\%+10\mu\text{V})/^{\circ}\text{C}$ on wide range models with internal programming resistors and on 5V thru 150V units.
remote programming resistance	1000 $\Omega$ /volt nominal. Downward programming to voltages less than 1 volt must be accomplished in two steps; first, from original voltage value to 1 volt, and then from 1 volt to final desired value.
remote programming voltage	volt/volt

### AC Input

line	105-127 VAC, 210-254 VAC (by transformer tap change) 47-440 Hz. Derate 40°C rating 10% for 50 Hz operation. Consult factory for 63-440 Hz ratings.
power	LDS-Y - 155 watts; LDS-X - 230 watts; LDS-W - 293 watts; LDS-P - 430 watts.

### Ambient Operating Temperature

Continuous duty from 0 to 60°C with appropriate deratings above 40°C (see tables).

### Storage Temperature

-55 to +85° C

### Overload Protection

#### THERMAL

By self resetting thermostat.

#### ELECTRICAL

External overload protection—automatic current limiting circuit limits output current to preset value, thereby providing protection for load as well as the power supply.

#### Overshoot

No overshoot at turn-on, turn-off, or power failure.

#### Cooling

Convection cooled—no fans or blowers required.

#### Transformer

MIL-T-27C, Grade 6. Electrostatic shield: 4000 VAC input/output isolation.

#### Isolation Rating

Minimum 10 Megohm isolation from DC to ground at 750 VDC.

#### Controls

Simple screwdriver adjustment over entire voltage range on fixed voltage models. On wide range models, an adjustable range of 1%-Vo max to Vo max is provided by the internal programming potentiometer; programming over the full 0 to Vo max range can be accomplished by remote programming.

## Input and Output Connections

Heavy duty screw terminals on PC board.

Solder turrets provide for remote programming operation.

### Remote Sensing

Provision is made for remote sensing to eliminate effect of power output lead resistance on DC regulation.

### Military Specifications

The LD series has been designed to pass the following tests in accordance with MIL-STD-810C

- 1) Low Pressure—Method 500.1, Procedure I.
- 2) High Temperature—Method 501.1, Procedure I & II.
- 3) Low Temperature—Method 502.1, Procedure I.
- 4) Temperature Shock—Method 503.1, Procedure I.
- 5) Temperature—Altitude—Method 504.1, Procedure I.

Class 2 (0°C operating)

- 6) Humidity—Method 507.1, Procedure I & II.
- 7) Fungus—Method 508.1, Procedure I.
- 8) Vibration—Method 514.2, Procedures X & XI.
- 9) Shock—Method 516.2, Procedures I & III.

MIL-I-6181D—Conducted and radiated EMI with one output terminal grounded.

### Mounting

LDS-Y, X, W—three mounting surfaces, three mounting positions (Two mounting surfaces on wide range and 48V models when used with optional adjustable LH OV).

LDS-P—one mounting surface, one mounting position.

### Physical Data

Package Model	Weight		Size Inches
	Lbs. Net	Lbs. Ship	
LDS-Y	5-1/2	6	5-5/8×4-7/8×2-5/8 w/cover 5-5/8×4-7/8×2-1/2 wo/cover
LDS-X	7-3/4	8-1/4	7×4-7/8×2-7/8 w/cover 7×4-7/8×2-3/4 wo/cover
LDS-W	9	9-1/2	9×5×2-7/8 w/cover 9×4-7/8×2-3/4 wo/cover
LDS-P	14	15-1/2	11×4-7/8×4-13/32 w & wo/cover

All units shipped with cover.

### Fungus Proofing

All units are fungi inert.

### Finish

Gray, Fed. Std. 595, No. 26081

### Options

AC Input: Unit can be rewired for 210-254 VAC at 47-440 Hz. Consult factory for operation above 63 Hz.

### Accessories

Overvoltage protection (standard on all 5V models)

POWER SUPPLY SERIES	OV SERIES
LDS-Y-12V thru 28V models	L-6-OV (Fixed)
LDS-X-12V thru 28V models	L-12-OV (Fixed)
LDS-W-12V thru 28V models	L-20-OV (Fixed)
LDS-P-12V thru 28V models	L-20-OV (Fixed)
All 01, 02, 03 and 48V models	LHOV (Adjustable)

For rack adaptors, chassis slides and blank panels, see page 68.

### Guaranteed for 5 years

5-year guarantee includes labor as well as parts. Guarantee applies to operation at full published specifications at end of 5 years.

### UL/Recognized

CSA-Certified (48V, 100V, 120V and 150V models presently under test)

# 5-year guaranteed linear selector guide

Single output wide range  
Models LD, LC and LM.

MODEL	REGULATION (line load)	RIPPLE (RMS)	40°C	MAX AMPS AT AMBIENT OF				COMPLETE ELEC. SPEC. PG	PKG. SIZE	DIMENSIONS (inches)	COMPLETE MECH. SPEC. PG	PRICE
				50°C	60°C	71°C						
<b>0-7 VOLTS ADJ.</b>												
LDS-Y-01 <sup>(16)</sup>	0.005% + 0.5 mV 0.005% + 0.5 mV	150 μV	3.4(3.4)	2.9(2.85)	2.4(1.8)	—	39	Y	5-5/8 x 4-7/8 x 2-5/8	123	233	
LDS-X-01 <sup>(16)</sup>	0.005% + 0.5 mV 0.005% + 0.5 mV	150 μV	4.8(4.1)	4.0(3.4)	3.1(2.6)	—	35	X	7 x 4-7/8 x 2-7/8	123	289	
LDS-W-01	0.005% + 0.5 mV 0.005% + 0.5 mV	150 μV	6.6 (5.6)	5.7(4.8)	4.5(3.8)	—	35	W	9 x 5 x 2-7/8	124	351	
LDS-P-01 <sup>(16)</sup>	0.005% + 0.5 mV 0.005% + 0.5 mV	150 μV	9.5(9.0)	8.5(8.0)	7.5(7.1)	—	35	P	11 x 4-7/8 x 4-13/32	124	440	
<b>0-18 VOLTS ADJ.</b>												
LDS-Y-02 <sup>(16)</sup>	0.005% + 0.5 mV 0.005% + 0.5 mV	150 μV	1.8(1.8)	1.6(1.6)	1.4(0.9)	—	35	Y	5-5/8 x 4-7/8 x 2-5/8	123	233	
LDS-X-02 <sup>(16)</sup>	0.005% + 0.5 mV 0.005% + 0.5 mV	150 μV	2.3(1.95)	1.9(1.6)	1.5(1.3)	—	35	X	7 x 4-7/8 x 2-7/8	123	289	
LDS-W-02 <sup>(16)</sup>	0.005% + 0.5 mV 0.005% + 0.5 mV	150 μV	3.2(2.7)	2.8(2.4)	2.2(1.9)	—	35	W	9 x 5 x 2-7/8	124	351	
LDS-P-02 <sup>(16)</sup>	0.005% + 0.5 mV 0.005% + 0.5 mV	150 μV	4.5(4.3)	4.0(3.8)	3.3(3.1)	—	35	P	11 x 4-7/8 x 4-13/32	124	440	

All outputs continuously adjustable over entire range. For other voltages or currents not listed see page 65 or consult your local Lambda Sales Engineer.

<sup>(16)</sup>Ratings in parenthesis for LD series when cover is used.

# 5-year guaranteed linear selector guide

## Single output wide range Models LD

MODEL	REGULATION (line load)	RIPPLE (RMS)	MAX AMPS AT AMBIENT OF				COMPLETE ELEC. SPEC. PG	PKG. SIZE	DIMENSIONS (inches)	COMPLETE MECH. SPEC. PG	PRICE
			40°C	50°C	60°C	71°C					
<b>0-32 VOLTS ADJ.</b>											
LDS-Y-03 <sup>(16)</sup>	0.005% + 0.5 mV 0.005% + 0.5 mV	150 μV	1.1(1.1)	1.0(0.95)	0.8(0.6)	—	35	Y	5-5/8 x 4-7/8 x 2-5/8	123	233
LDS-X-03 <sup>(16)</sup>	0.005% + 0.5 mV 0.005% + 0.5 mV	150 μV	1.5(1.25)	1.3(1.1)	1.1(0.95)	—	35	X	7 x 4-7/8 x 2-7/8	123	289
LDS-W-03 <sup>(16)</sup>	0.005% + 0.5 mV 0.005% + 0.5 mV	150 μV	2.1(1.8)	1.9(1.5)	1.4(1.2)	—	35	W	9 x 5 x 2-7/8	124	351
LDS-P-03 <sup>(16)</sup>	0.005% + 0.5 mV 0.005% + 0.5 mV	150 μV	2.7(2.5)	2.5(2.4)	2.3(2.2)	—	35	P	11 x 4-7/8 x 4-13/32	124	440
<b>5 VOLTS ± 5% ADJ.</b>											
LDS-Y-5-0V <sup>(16)</sup>	0.005% + 0.5 mV 0.005% + 0.5 mV	150 μV	5.4(5.0)	4.4(4.0)	3.3(3.0)	—	35	Y	5-5/8 x 4-7/8 x 2-5/8	123	233
LDS-X-5-0V <sup>(16)</sup>	0.005% + 0.5 mV 0.005% + 0.5 mV	150 μV	10.0(8.5)	8.6(7.3)	7.0(6.0)	—	35	X	7 x 4-7/8 x 2-7/8	123	289
LDS-W-5-0V <sup>(16)</sup>	0.005% + 0.5 mV 0.005% + 0.5 mV	150 μV	14.0(11.9)	11.7(9.9)	9.1(7.7)	—	35	W	9 x 5 x 2-7/8	124	351
LDS-P-5-0V <sup>(16)</sup>	0.005% + 0.5 mV 0.005% + 0.5 mV	150 μV	22.0(20.9)	18.8(18.0)	15.6(14.8)	—	35	P	11 x 4-7/8 x 4-13/32	124	440

All outputs continuously adjustable over entire range. For other voltages or currents not listed see page 65 or consult your local Lambda Sales Engineer.  
<sup>(16)</sup>Ratings in parenthesis for LD series when cover is used.

# 5-year guaranteed linear selector guide

Single output fixed voltage  
Models LD, LN, LC, LX and LM.

MODEL	REGULATION (line, load)	RIPPLE (RMS)	MAX AMPS AT AMBIENT OF				COMPLETE ELEC. SPEC. PG	PKG. SIZE	DIMENSIONS (inches)	COMPLETE MECH. SPEC. PG	PRICE
			40°C	50°C	60°C	71°C					
<b>5 VOLTS ±5% ADJ.</b>											
LDS-Y-5-OV <sup>(16)</sup>	0.005%+0.5 mV 0.005%+0.5 mV	150 μV	5.4(5.0)	4.4(4.0)	3.3(3.0)	—	35	Y	5-5/8 x 4-7/8 x 2-5/8	123	233
LDS-X-5-OV <sup>(16)</sup>	0.005%+0.5 mV 0.005%+0.5 mV	150 μV	10.0(8.5)	8.6(7.3)	7.0(6.0)	—	35	X	7 x 4-7/8 x 2-7/8	123	289
LDS-W-5-OV <sup>(16)</sup>	0.005%+0.5 mV 0.005%+0.5 mV	150 μV	14.0(11.9)	11.7(9.9)	9.1(7.7)	—	35	W	9 x 5 x 2-7/8	124	351
LDS-P-5-OV <sup>(16)</sup>	0.005%+0.5 mV 0.005%+0.5 mV	150 μV	22.0(20.9)	18.8(18.0)	15.6(14.8)	—	35	P	11 x 4-7/8 x 4-13/32	124	440

(2,3,4,5,11,14) See page 33. For other voltages or currents not listed see page 65 or consult your local Lambda Sales Engineer.  
(16) Ratings in parenthesis for LD and LN series when cover is used.

# 5-year guaranteed linear selector guide

## Single output fixed voltage Models LD

MODEL	REGULATION (line, load)	RIPPLE (RMS)	MAX AMPS AT AMBIENT OF				COMPLETE ELEC. SPEC. PG	PKG. SIZE	DIMENSIONS (inches)	COMPLETE MECH. SPEC. PG	PRICE
			40°C	50°C	60°C	71°C					
<b>12 VOLTS ± 5% ADJ.</b>											
LDS-Y-12 <sup>(16)</sup>	0.005% + 0.5 mV 0.005% + 0.5 mV	150 μV	3.7(3.4)	2.9(2.55)	2.0(1.75)	—	35	Y	5-5/8 x 4-7/8 x 2-5/8	123	223
LDS-X-12 <sup>(16)</sup>	0.005% + 0.5 mV 0.005% + 0.5 mV	150 μV	6.5(5.5)	5.5(4.7)	4.5(3.8)	—	35	X	7 x 4-7/8 x 2-7/8	123	278
LDS-W-12 <sup>(16)</sup>	0.005% + 0.5 mV 0.005% + 0.5 mV	150 μV	8.5(7.2)	7.0(6.0)	5.3(4.5)	—	35	W	9 x 5 x 2-7/8	124	339
LDS-P-12 <sup>(16)</sup>	0.005% + 0.5 mV 0.005% + 0.5 mV	150 μV	14.0(13.3)	12.4(11.8)	10.0(9.5)	—	35	P	11 x 4-7/8 x 4-13/32	124	428

<sup>(11)</sup> See page 33. For other voltages or currents not listed see page 65 or consult your local Lambda Sales Engineer.

<sup>(16)</sup> Ratings in parenthesis for LD and LN series when cover is used.

# 5-year guaranteed linear selector guide

Single output fixed voltage  
Models LD, LN, LC, LX and LM.

MODEL	REGULATION (line load)	RIPPLE (RMS)	MAX AMPS AT AMBIENT OF				COMPLETE ELEC. SPEC. PG	PKG. SIZE	DIMENSIONS (inches)	COMPLETE MECH. SPEC. PG	PRICE
			40°C	50°C	60°C	71°C					
<b>15 VOLTS ±5% ADJ.</b>											
LDS-Y-15 <sup>116</sup>	0.005%+0.5 mV 0.005%+0.5 mV	150 μV	3.25(3.0)	2.5(2.25)	1.7(1.55)	—	35	Y	5-5/8 x 4-7/8 x 2-5/8	123	223
LDS-X-15 <sup>116</sup>	0.005%+0.5 mV 0.005%+0.5 mV	150 μV	5.5(4.7)	4.6(3.9)	3.6(3.1)	—	35	X	7 x 4-7/8 x 2-7/8	123	278
LDS-W-15 <sup>116</sup>	0.005%+0.5 mV 0.005%+0.5 mV	150 μV	7.7(6.55)	6.2(5.3)	4.7(4.0)	—	35	W	9 x 5 x 2-7/8	124	339
LDS-P-15 <sup>116</sup>	0.005%+0.5 mV 0.005%+0.5 mV	150 μV	12.0(11.4)	10.6(10.0)	8.5(8.1)	—	35	P	11 x 4-7/8 x 4-13/32	124	428
<b>20 VOLTS ±5% ADJ.</b>											
LDS-Y-20 <sup>116</sup>	0.005%+0.5 mV 0.005%+0.5 mV	150 μV	2.5(2.25)	2.0(1.8)	1.5(1.35)	—	35	Y	5-5/8 x 4-7/8 x 2-5/8	123	223
LDS-X-20 <sup>116</sup>	0.005%+0.5 mV 0.005%+0.5 mV	150 μV	4.4(3.7)	3.6(3.1)	2.6(2.2)	—	35	X	7 x 4-7/8 x 2-7/8	123	278
LDS-W-20 <sup>116</sup>	0.005%+0.5 mV 0.005%+0.5 mV	150 μV	6.1(5.2)	5.0(4.3)	3.8(3.2)	—	35	W	9 x 5 x 2-7/8	124	339
LDS-P-20 <sup>116</sup>	0.005%+0.5 mV 0.005%+0.5 mV	150 μV	10.0(9.5)	8.9(8.5)	7.0(6.6)	—	35	P	11 x 4-7/8 x 4-13/32	124	428

<sup>114,115,116</sup> See page 33. For other voltages or currents not listed see page 65 or consult your local Lambda Sales Engineer.

<sup>116</sup> Ratings in parenthesis for LD and LN series when cover is used

# 5-year guaranteed linear selector guide

## Single output fixed voltage Models LD

MODEL	REGULATION (line, load)	RIPPLE (RMS)	MAX AMPS AT AMBIENT OF				COMPLETE ELEC. SPEC. PG	PKG. SIZE	DIMENSIONS (inches)	COMPLETE MECH. SPEC. PG	PRICE
			40°C	50°C	60°C	71°C					
<b>24 VOLTS ± 5% ADJ.</b>											
LDS-Y-24 <sup>(16)</sup>	0.005%+0.5 mV 0.005%+0.5 mV	150 μV	2.1(1.9)	1.7(1.55)	1.3(1.15)	—	35	Y	5-5/8 x 4-7/8 x 2-5/8	123	223
LDS-X-24 <sup>(16)</sup>	0.005%+0.5 mV 0.005%+0.5 mV	150 μV	3.8(3.2)	3.2(2.7)	2.4(2.0)	—	35	X	7 x 4-7/8 x 2-7/8	123	278
LDS-W-24 <sup>(16)</sup>	0.005%+0.5 mV 0.005%+0.5 mV	150 μV	5.4(4.8)	4.4(3.7)	3.3(2.8)	—	35	W	9 x 5 x 2-7/8	124	339
LDS-P-24 <sup>(16)</sup>	0.005%+0.5 mV 0.005%+0.5 mV	150 μV	9.0(8.5)	8.0(7.5)	6.0(5.7)	—	35	P	11 x 4-7/8 x 4-13/32	124	428
<b>28 VOLTS ± 5% ADJ.</b>											
LDS-Y-28 <sup>(16)</sup>	0.005%+0.5 mV 0.005%+0.5 mV	150 μV	1.9(1.65)	1.5(1.35)	1.1(1.0)	—	35	Y	5-5/8 x 4-7/8 x 2-5/8	123	223

28 Volts ± 5% continued next page.

<sup>(1), (2)</sup> See page 33. For other voltages or currents not listed see page 65 or consult your local Lambda Sales Engineer

<sup>(16)</sup> Ratings in parenthesis for LD and LN series when cover is used.



# 5-year guaranteed linear selector guide

## Single output fixed voltage Models LD, LN, LC, LX and LM

MODEL	REGULATION (line, load)	RIPPLE (RMS)	MAX AMPS AT AMBIENT OF				COMPLETE ELEC. SPEC. PG	PKG. SIZE	DIMENSIONS (inches)	COMPLETE MECH. SPEC. PG	PRICE
			40°C	50°C	60°C	71°C					
<b>28 VOLTS ±5% ADJ. (Cont'd)</b>											
LDS-X-28 <sup>(16)</sup>	0.005%+0.5 mV 0.005%+0.5 mV	150 μV	3.4(2.9)	2.9(2.5)	2.2(1.9)	—	35	X	7 x 4-7/8 x 2-7/8	123	278
LDS-W-28 <sup>(16)</sup>	0.005%+0.5 mV 0.005%+0.5 mV	150 μV	4.7(4.0)	4.0(3.4)	3.1(2.6)	—	35	W	9 x 5 x 2-7/8	124	339
LDS-P-28 <sup>(16)</sup>	0.005%+0.5 mV 0.005%+0.5 mV	150 μV	8.0(7.6)	7.1(6.7)	5.2(4.9)	—	35	P	11 x 4-7/8 x 4-13/32	124	428
<b>48 VOLTS ±5% ADJ.</b>											
LDS-Y-48	0.005%+0.5 mV	150 μV	1.36(1.2)	1.05(0.95)	0.75(0.70)	—	35	Y	5-5/8 x 4-7/8 x 2-5/8	123	233
LDS-X-48	0.005%+0.5 mV	150 μV	2.1(1.9)	1.8(1.6)	1.4(1.2)	—	35	X	7 x 4-7/8 x 2-7/8	123	289
LDS-W-48	0.005%+0.5 mV	150 μV	3.0(2.6)	2.6(2.2)	2.0(1.7)	—	35	W	9 x 5 x 2-7/8	124	351
LDS-P-48	0.005%+0.5 mV	150 μV	4.5(4.28)	4.0(3.8)	3.4(3.2)	—	35	P	11 x 4-7/8 x 4-13/32	124	448

<sup>(2,3,7,19)</sup> See page 33. For other voltages or currents not listed see page 65 or consult your local Lambda Sales Engineer.

<sup>(16)</sup> Ratings in parenthesis for LN series when cover is used.

# 5-year guaranteed linear selector guide

## Single output fixed voltage Models LD, LN, LC, LX and LM

MODEL	REGULATION (line load)	RIPPLE (RMS)	MAX AMPS AT AMBIENT OF				COMPLETE ELEC. SPEC. PG	PKG. SIZE	DIMENSIONS (inches)	COMPLETE MECH. SPEC. PG	PRICE
			40°C	50°C	60°C	71°C					
<b>100 VOLTS ± 5% ADJ.</b>											
LDS-Y-100	0.005%+0.5 mV	250 μV	0.55(0.55)	0.45(0.45)	0.35(0.35)	—	35	Y	5-5/8 × 4-7/8 × 2-5/8	123	249
LDS-P-100	0.005%+0.5 mV	250 μV	1.6(1.6)	1.4(1.4)	1.2(1.2)	—	35	P	5-5/8 × 4-7/8 × 2-5/8	123	455
<b>120 VOLTS ± 5% ADJ.</b>											
LDS-Y-120	0.005%+0.5 mV	250 μV	.45(.45)	.35(.35)	.25(.25)	—	35	Y	5-5/8 × 4-7/8 × 2-5/8	123	249
LDS-P-120	0.005%+0.5 mV	250 μV	1.4(1.4)	1.2(1.2)	1.0(1.0)	—	35	P	5-5/8 × 4-7/8 × 2-5/8	123	455
<b>150 VOLTS ± 5% ADJ.</b>											
LDS-Y-150	0.005%+0.5 mV	250 μV	.35(.35)	.25(.25)	.15(.15)	—	35	Y	5-5/8 × 4-7/8 × 2-5/8	123	249
LDS-P-150	0.005%+0.5 mV	250 μV	1.1(1.1)	.9(.9)	.8(.8)	—	35	P	5-5/8 × 4-7/8 × 2-5/8	123	455

All outputs continuously adjustable over entire range. For other voltages or currents not listed see page 65 or consult your local Lambda Sales Engineer.



# PART IV—DIMENSIONAL DRAWINGS LDS-P AND LDS-W SERIES POWER SUPPLIES

## LDS-P SERIES

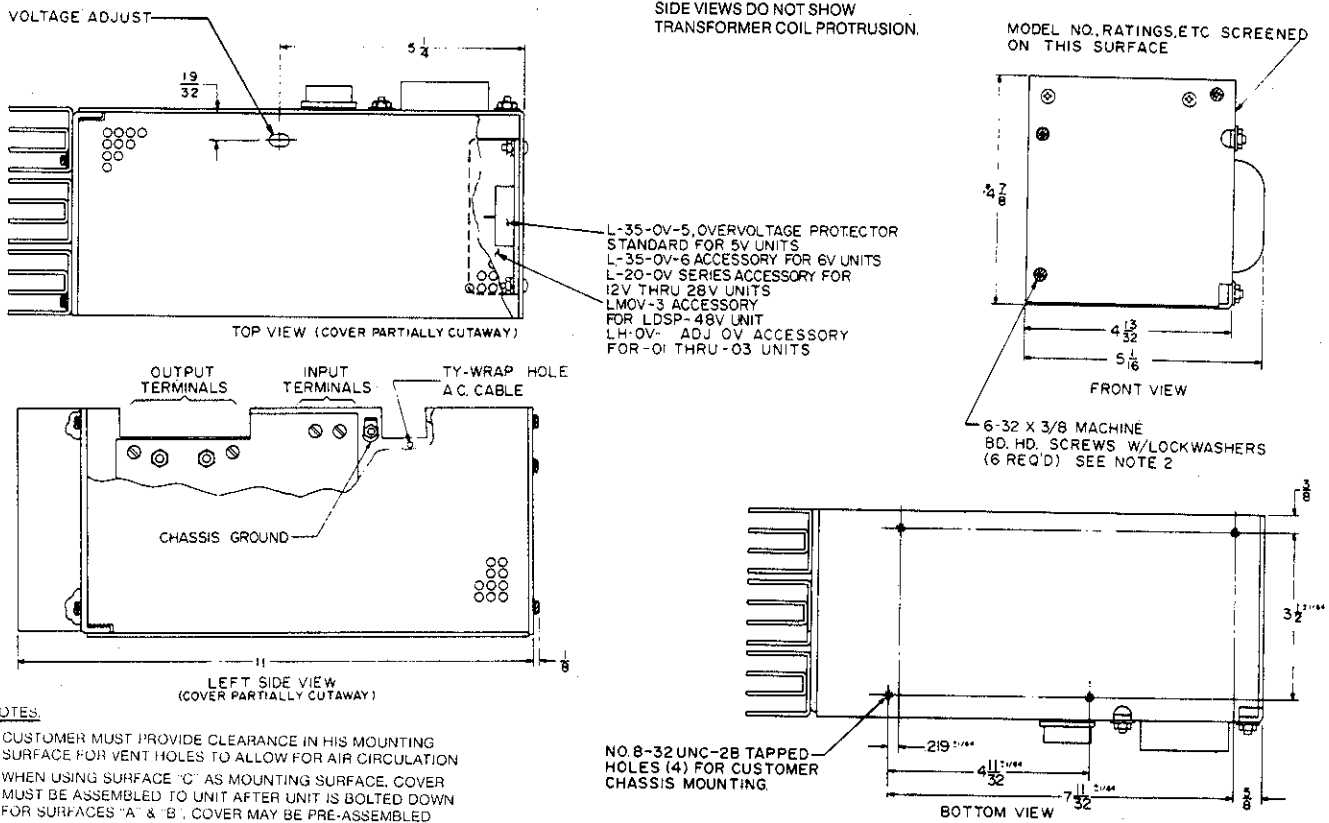

### NOTES:

- 1 CUSTOMER MUST PROVIDE CLEARANCE IN HIS MOUNTING SURFACE FOR VENT HOLES TO ALLOW FOR AIR CIRCULATION
- 2 WHEN USING SURFACE "C" AS MOUNTING SURFACE, COVER MUST BE ASSEMBLED TO UNIT AFTER UNIT IS BOLTED DOWN FOR SURFACES "A" & "B". COVER MAY BE PRE-ASSEMBLED TO UNIT

## LDS-W SERIES

